

VERRICELLO ELETTRICO TRIFASE 400V/50HZ

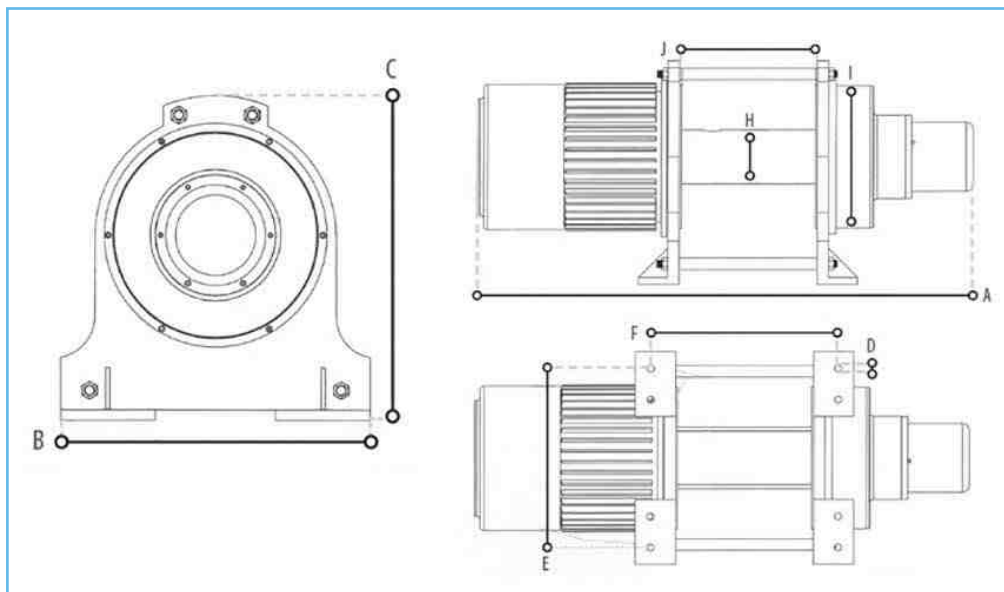

| CODICE | PORTATA (kg) | Velocità m/min | Potenza motore | | DIMENSIONI (mm) | | | | | | | | | DIMENSIONE CAVO | ASSORBIMENTO IN PARTENZA P/H | PESO (kg) |
|----------|--------------|----------------|----------------|-------|-----------------|-----|-----|-----|-----|-----|------|------|-----|-----------------|------------------------------|-----------|
| | | | Hp | Kw | A | B | C | D | E | F | H | I | J | | | |
| NVET2000 | 2000 | 12 | 5x6 | 3.729 | 1290 | 590 | 520 | Ø25 | 540 | 480 | Ø140 | Ø390 | 375 | 12mm/70m | 300 | 364 |